

ラム寸法図

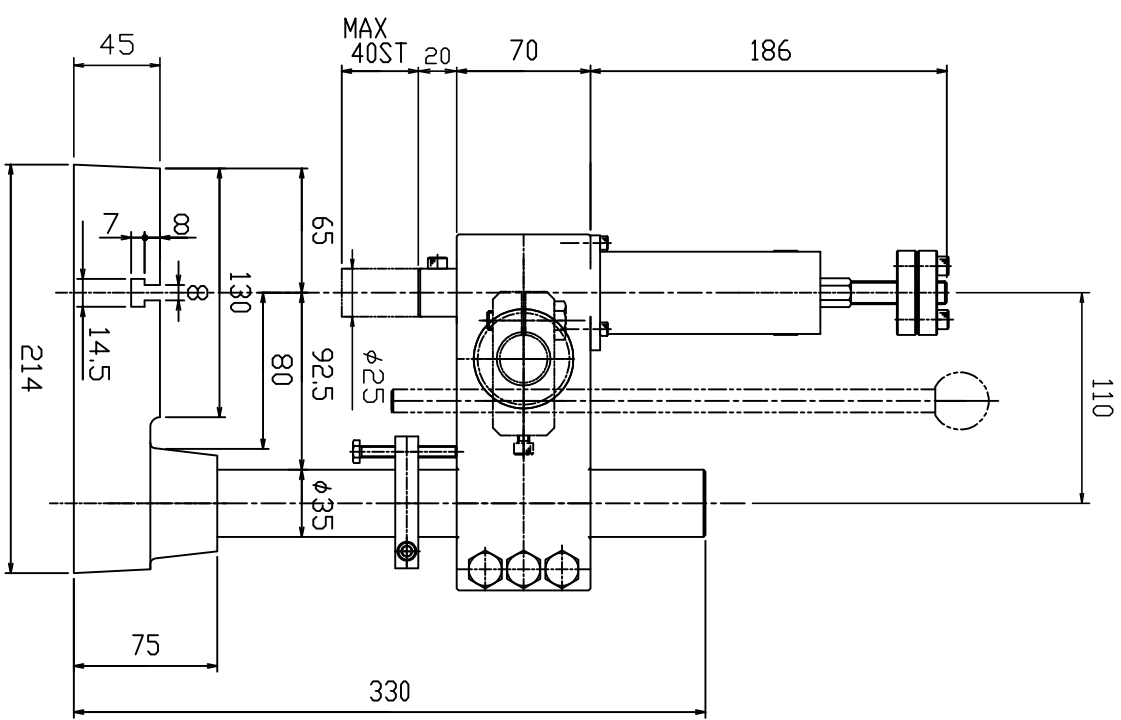

指示キキ面ハC トスル

FINISHING	TREATMENT	MATERIAL	QUANTITY	CUSTOMER
SCALE	DATE	MACHINE NAME		
1/2		H-1		
APPROVED BY		PARTS NAME		
CHECKED BY		外 観		
DRAWN BY		PARTS NO		
A2				

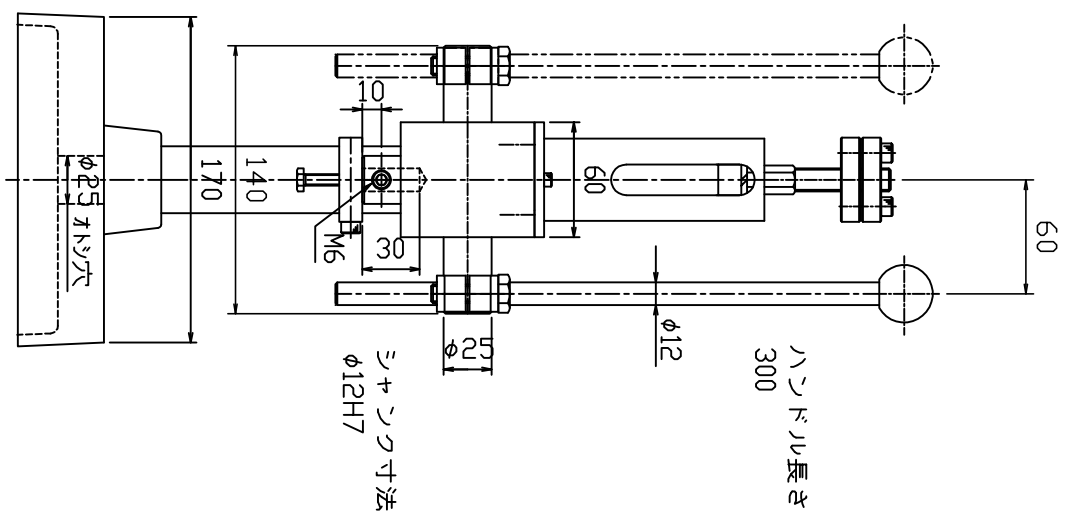
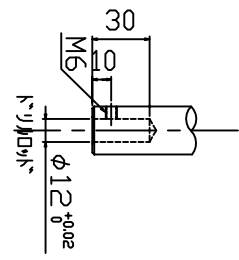
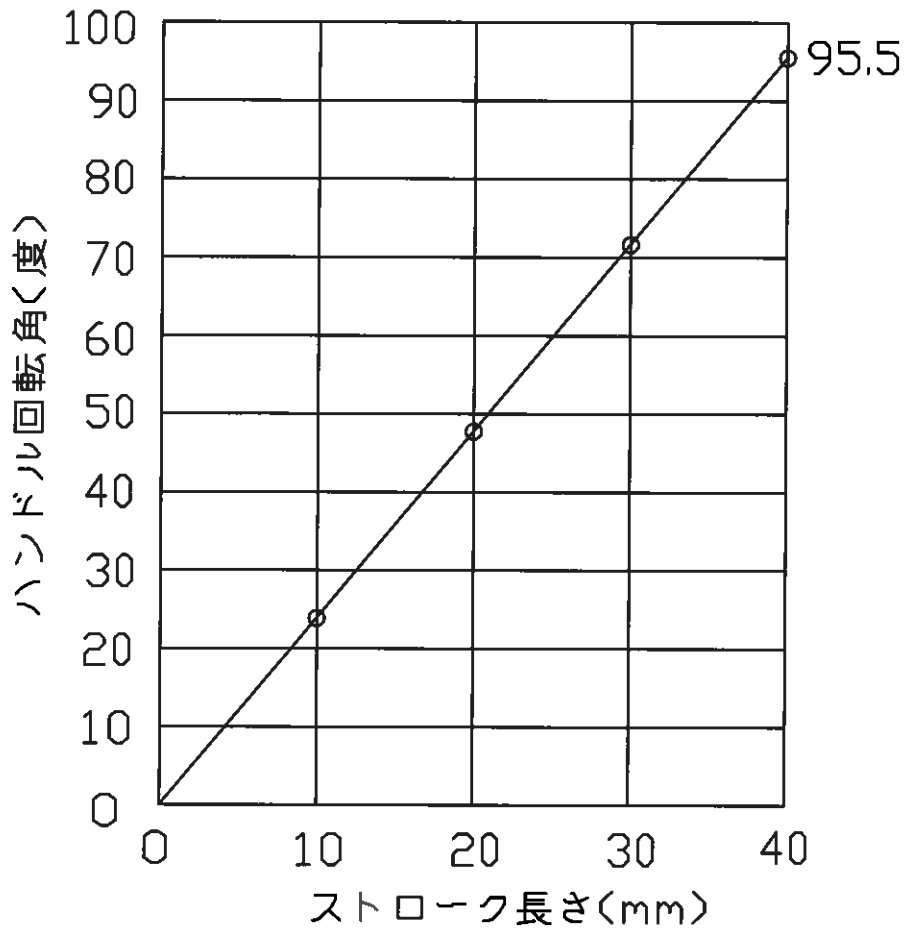

H-1

$$\text{ハンドル回転角(度)} = \frac{360 \times \text{ストローク長さ(mm)}}{48 \times \pi}$$

$$\text{ストローク長さ(mm)} = \frac{\text{ハンドル回転角(度)} \times 48 \times \pi}{360}$$

FINISHING		TREATMENT		MATERIAL		QUANTITY		MACHINE NAME		
△				SCALE		DATE		UNIT NAME		
△				MATEX					PARTS NAME	
△									PARTS NO	
THIRD ANGLE PROJECTION				CHECKED BY	DESIGNED BY	DRAWN BY	A4		CODE	PARTS NO

H-1

$$F(\text{kgf}) = \frac{W(\text{kgf}) \times 48}{2 \times 230}$$

W=100(kgf)の時

$$F(\text{kgf}) = \frac{100(\text{kgf}) \times 48}{2 \times 230}$$

$$= 10.43(\text{kgf})$$

H-1L

$$F(\text{kgf}) = \frac{W(\text{kgf}) \times 72}{2 \times 230}$$

W=100(kgf)の時

$$F(\text{kgf}) = \frac{100(\text{kgf}) \times 72}{2 \times 230}$$

$$= 15.65(\text{kgf})$$

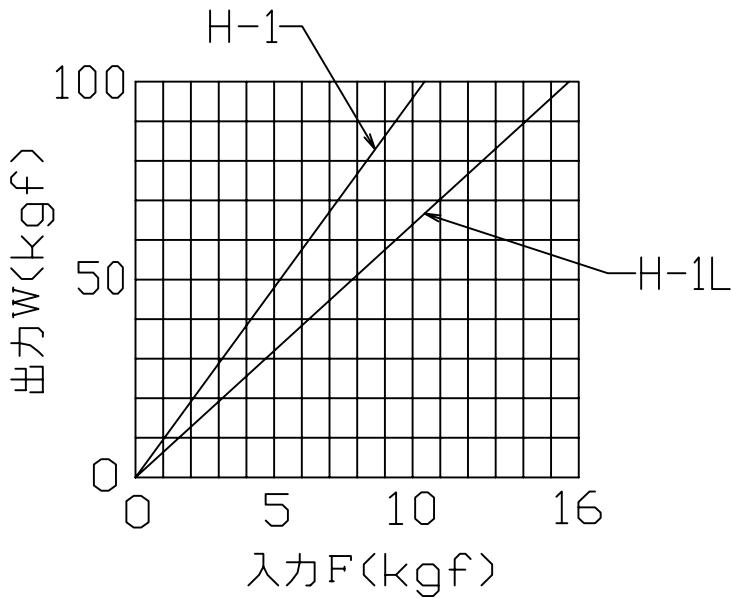
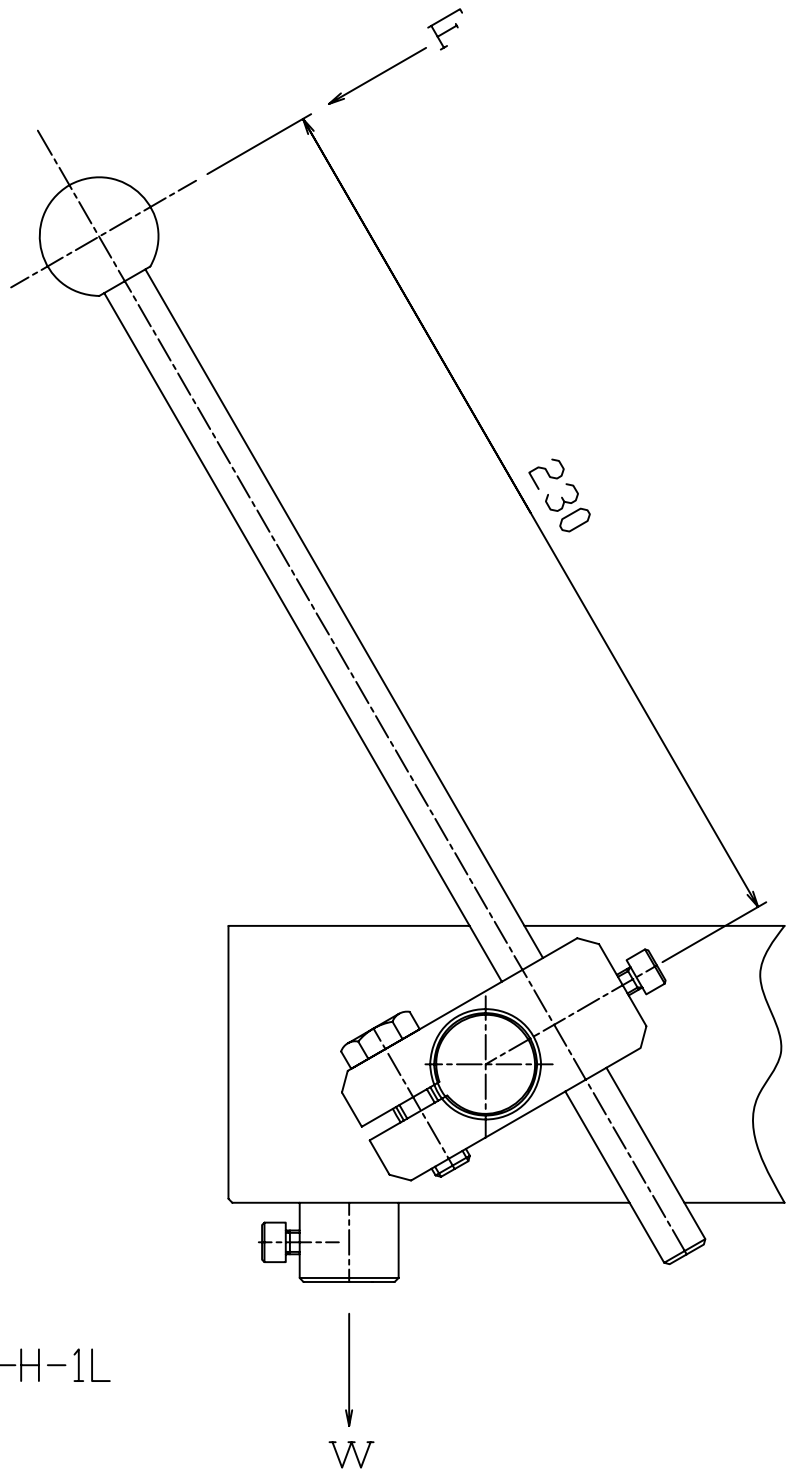

FINISHING		TREATMENT		MATERIAL		QUANTITY		MACHINE NAME	
△				SCALE		DATE		UNIT NAME	
△				MATEX				PARTS NAME	
△								PARTS NO	
THIRD ANGLE PROJECTION				CHECKED BY	DESIGNED BY	DRAWN BY	A4		