

ラム下面

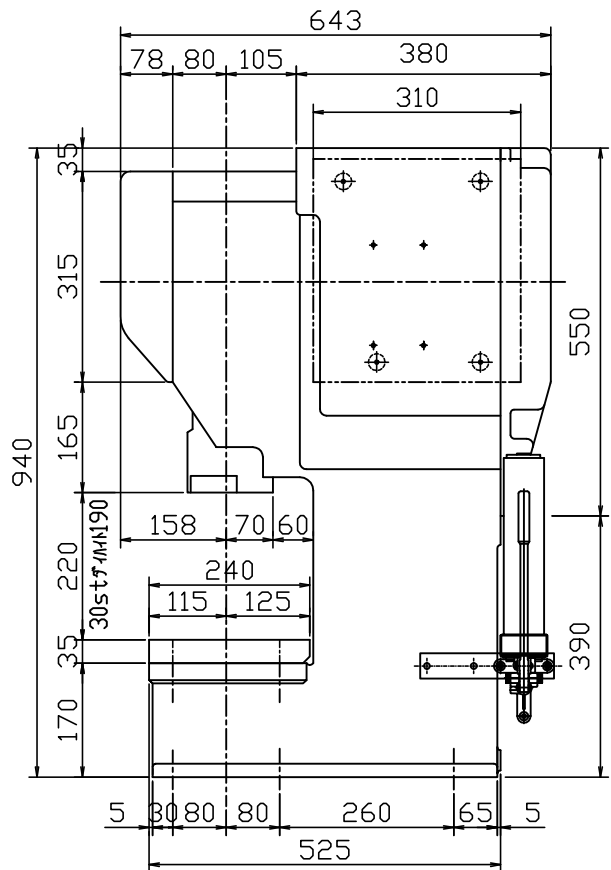

ボルスター

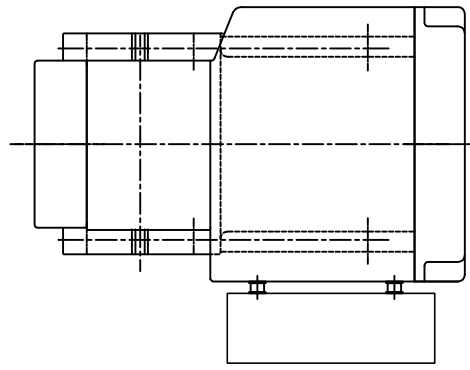
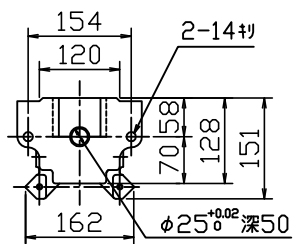
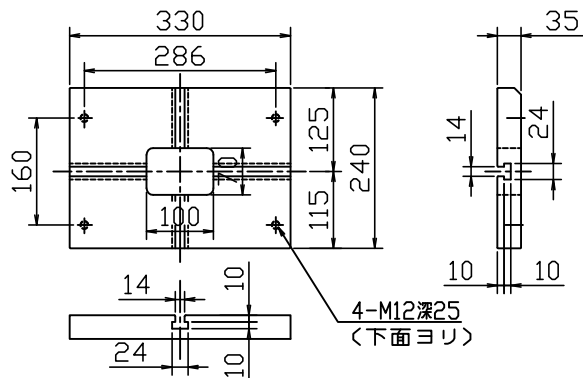

指示ナキ角及び稜線部は仕上げ時系面取りのこと(必ず)

FINISHING	TREATMENT	MATERIAL	QUANTITY	CUSTOMER
				B-55型プレス
MACHINE NAME				
UNIT NAME 全体				
PARTS NAME 外観				
PARTS NO B55-000A				
△ 組立検査し	2022/05/25	SCALE 1/4	DATE	
△		MATELBY		
△		CHECKED BY	DESIGNED BY	DRAWN BY
△				A1

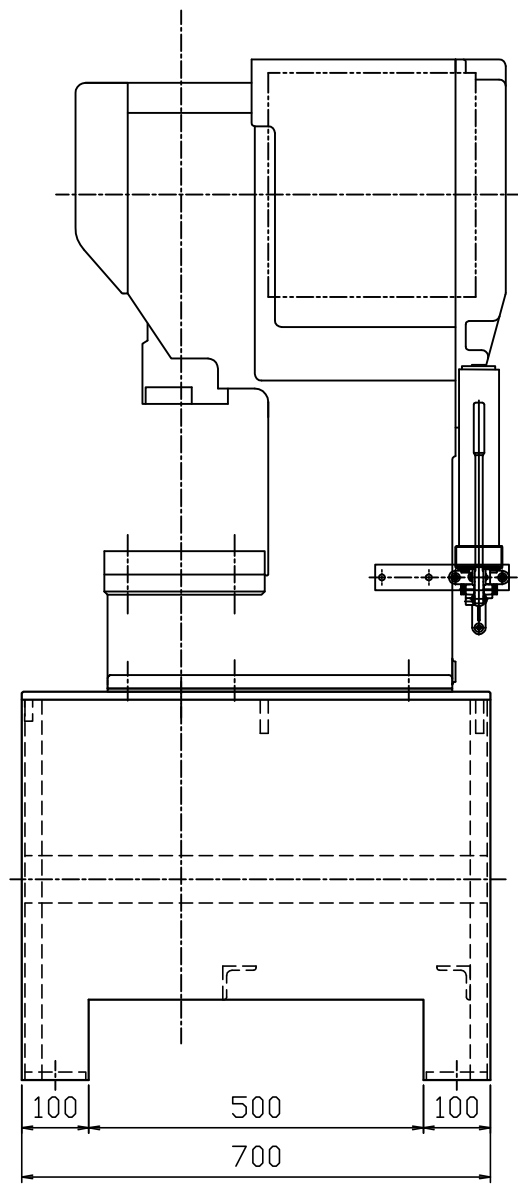
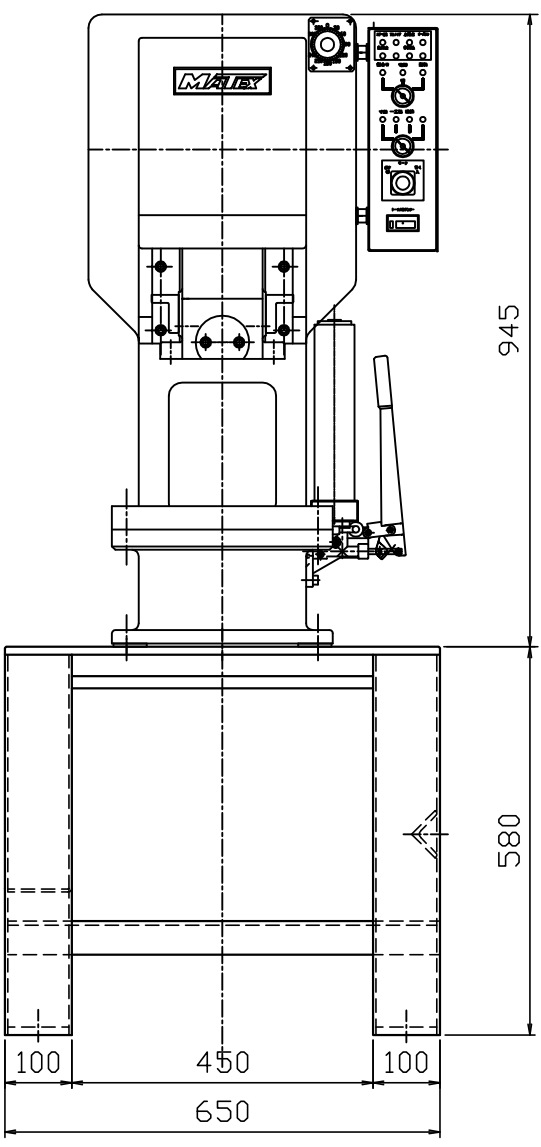
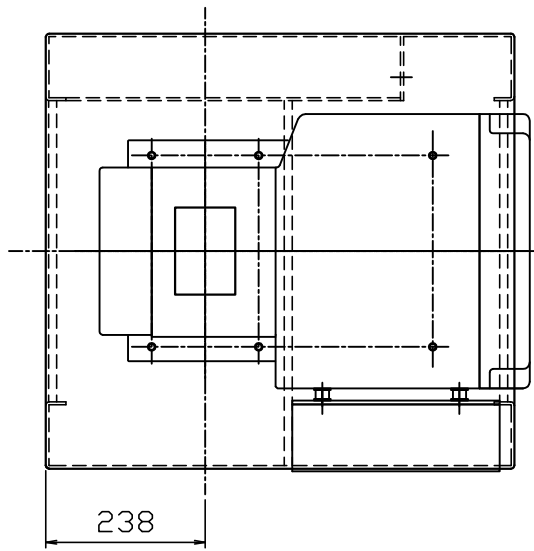

FINISHING	TREATMENT	MATERIAL	QUANTITY	MACHINE NAME
				B-55型プレス
SCALE 1/4		DATE	UNIT NAME	
CHECKED BY		DESIGNED BY	PARTS NAME 外觀図	
DRAWN BY		DATE	PARTS NO	
A1		名古屋		

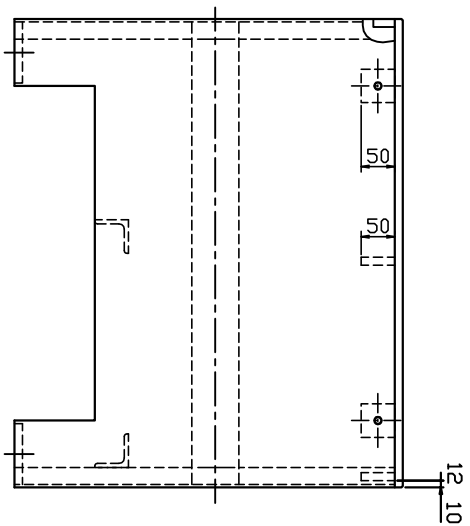
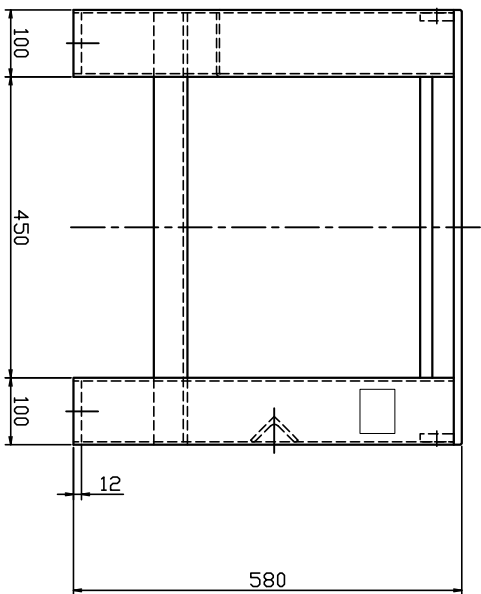
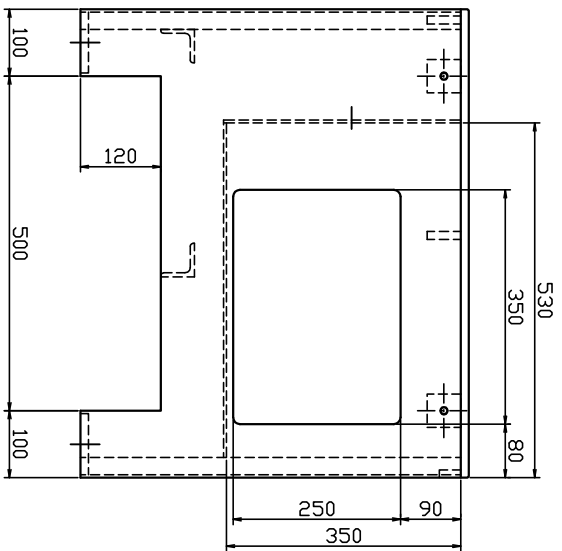
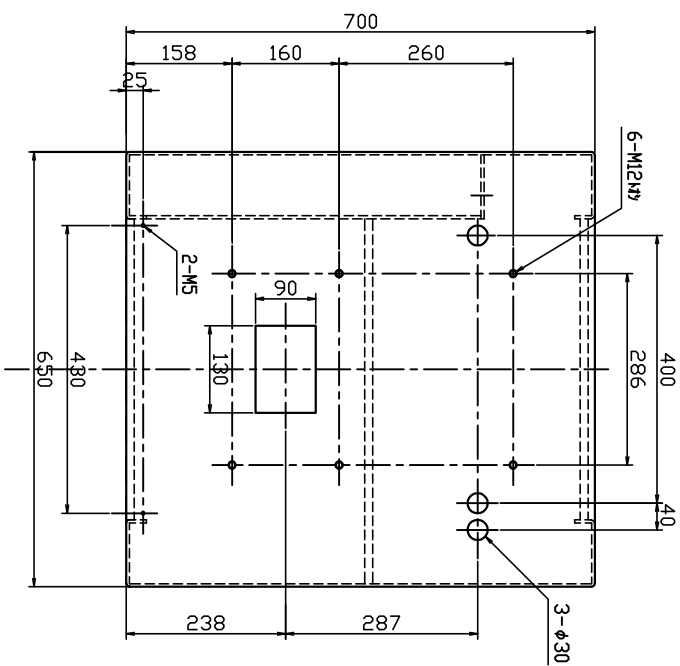

FINISHING	TREATMENT	MATERIAL	QUANTITY	CUSTOMER
~	塗装	SS400	1	指折子牛角部△C0.5トZJW
SCALE	1/4	DATE		
DESIGN	DESIGNER	NAME		
MA-B-55-001				
UNIT NAME	MACHINE NAME	B-557LZ		
PARTS NAME	B-55架台(標準)			
PARTS NO	MA-B-55-001			