

ラム 寸法図

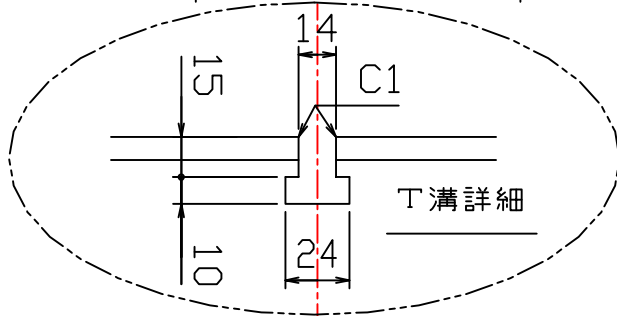
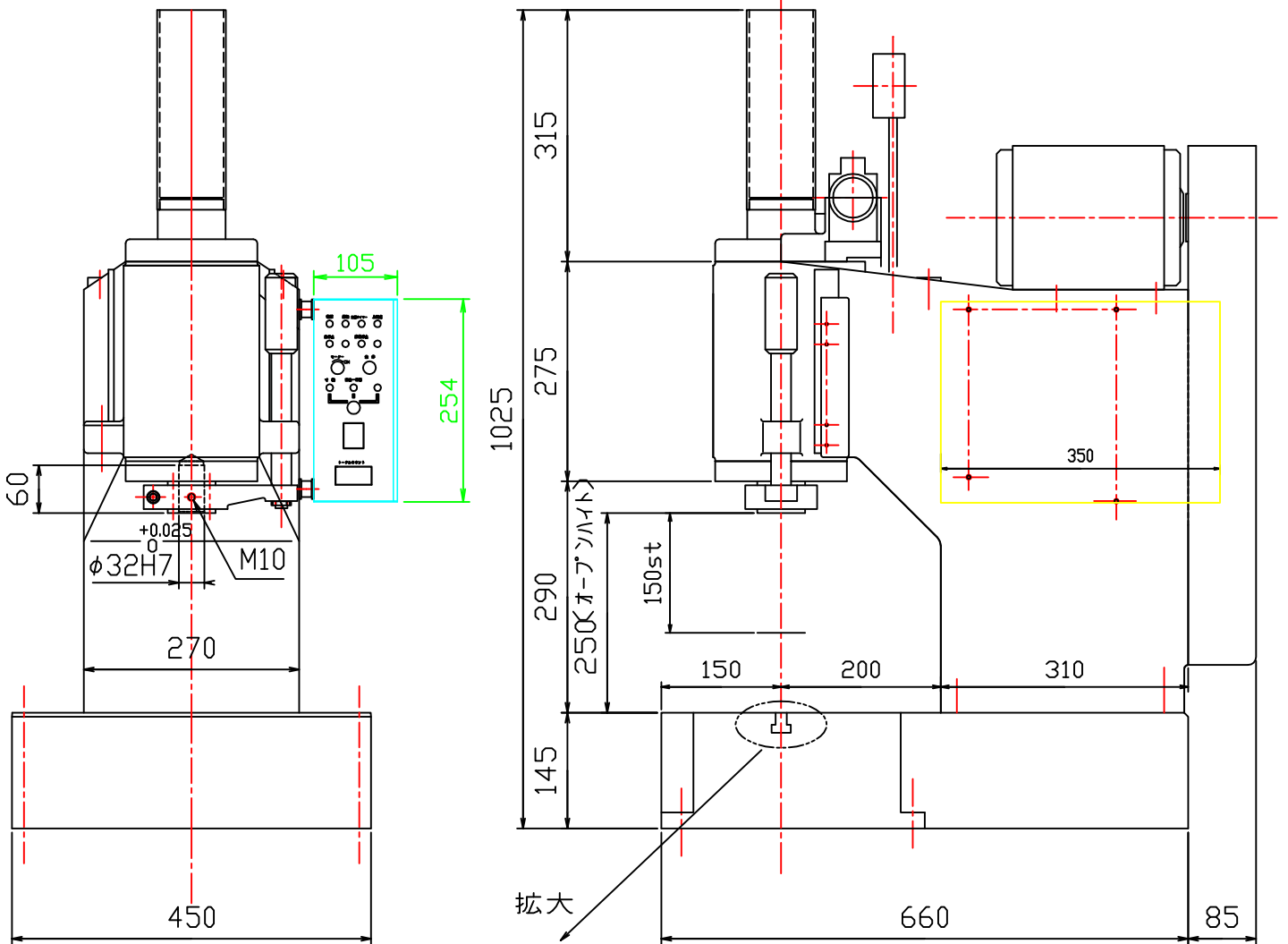
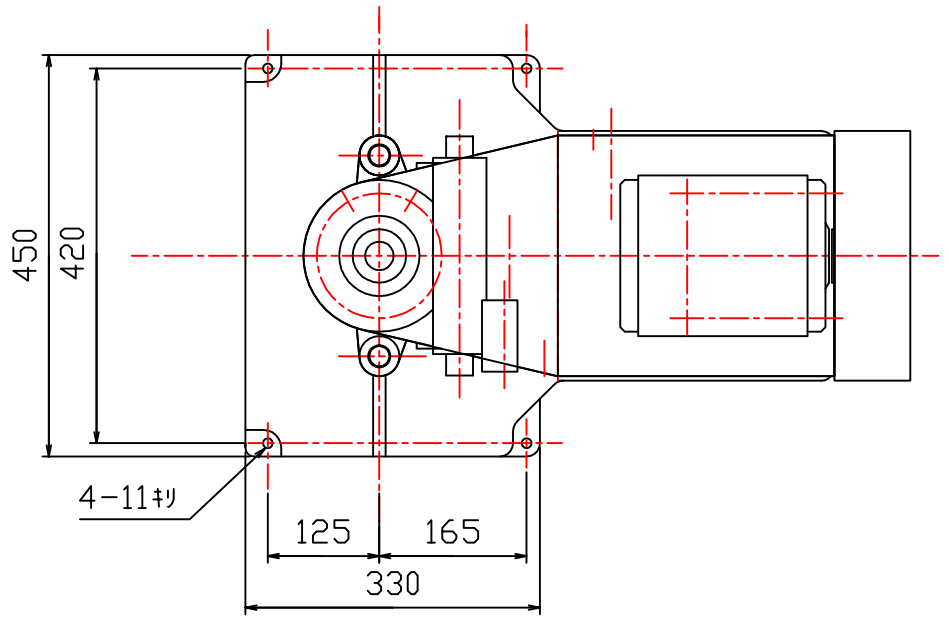
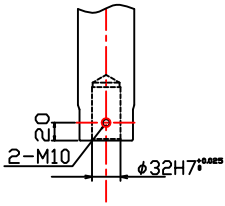

FINISHING	TREATMENT	MATERIAL	QUANTITY	MACHINE NAME
				A-5型
		SCALE	DATE	UNIT NAME
				PARTS NAME
				外觀図
THIRD ANGLE PROJECTION	CHECKED BY	DESIGNED BY	DRAWN BY	DATE
				A1

圧力荷重換算表

出力(KN) 49KN

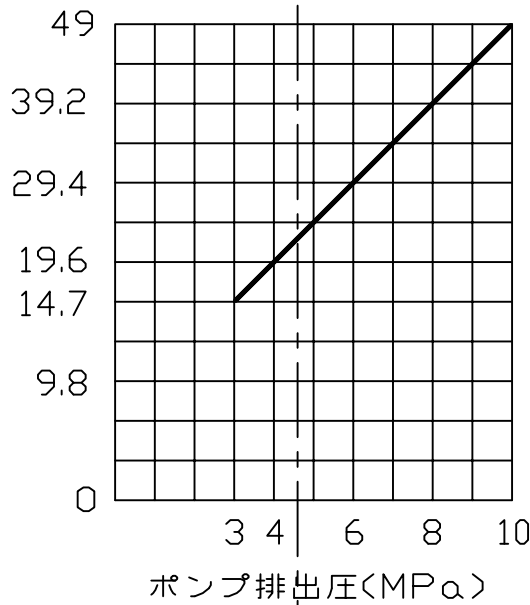

株式会社 マテックス精工

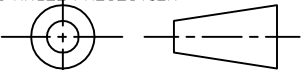
FINISHING		TREATMENT		MATERIAL		QUANTITY		MACHINE NAME	
						1		A-5標準プレス	
△		SCALE		DATE		UNIT NAME			
△		1/1							
△				PARTS NAME					
				銘板<圧力表>					
THIRD ANGLE PROJECTION		CHECKED BY		DESIGNED BY		DRAWN BY		CODE	
						A4		PARTS NO	
								A5-032	

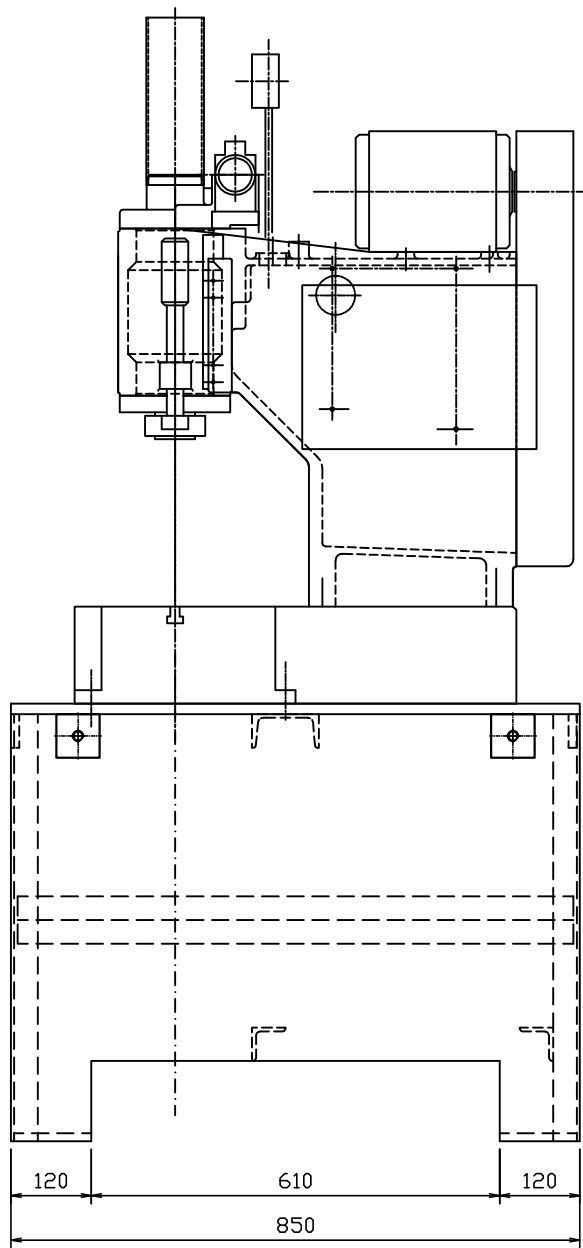
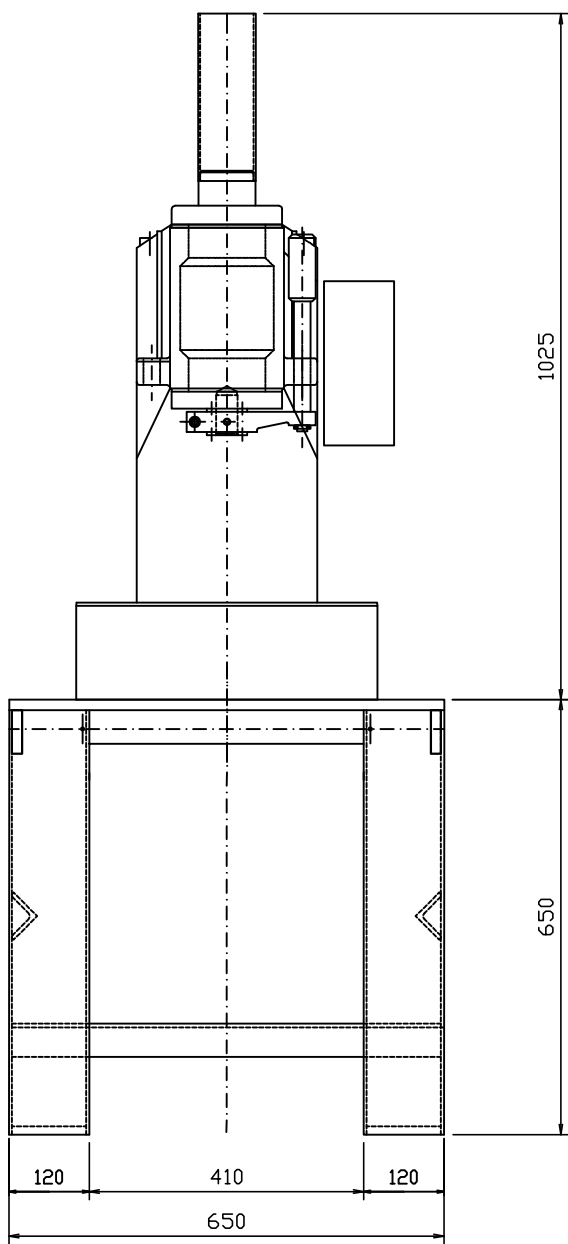
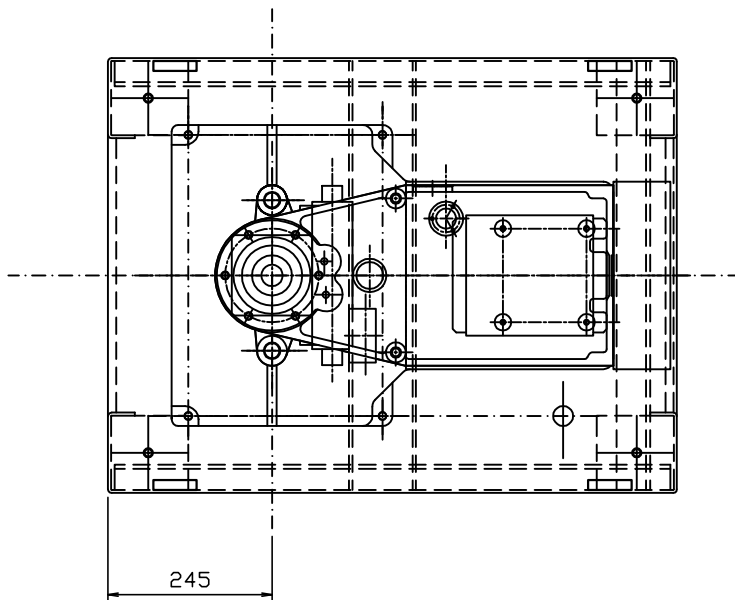

指示なき角及び稜線部は仕上げ時糸面取りのこと（必ず）

FINISHING	TREATMENT	MATERIAL	QUANTITY	MACHINE NAME
				A-5型プレス
△		SCALE 1/4	DATE	UNIT NAME
△		MATEX		PARTS NAME
△		CHECKED BY	DESIGNED BY	DRAWN BY
				外観図
			A1	PARTS NO

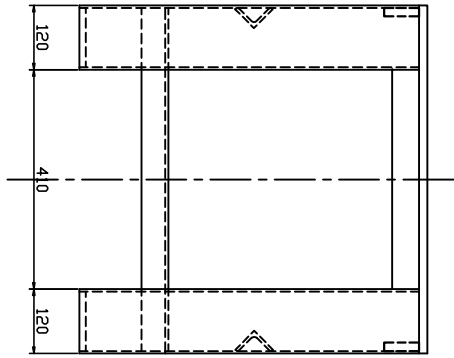

後面

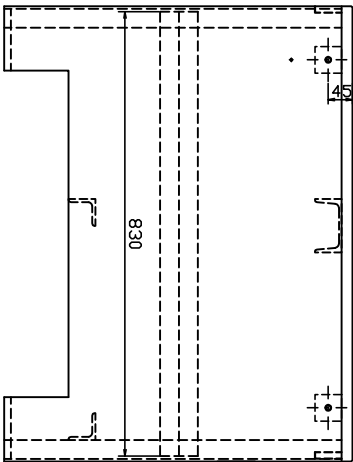
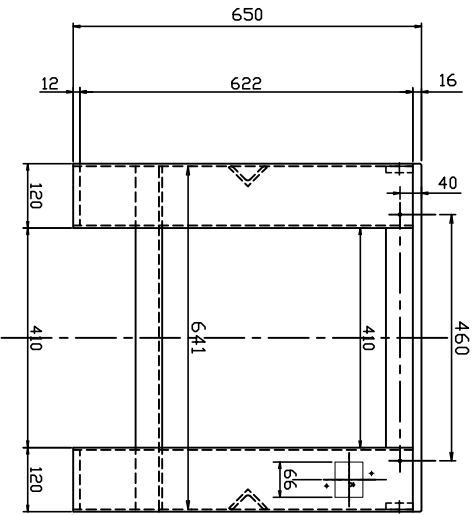
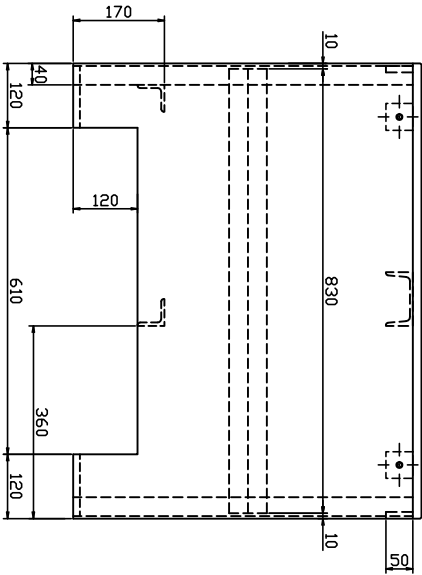
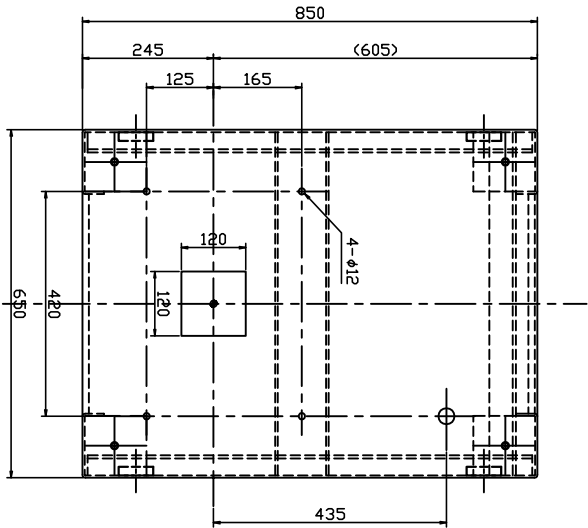

指示方向面ハCO5ト2J4

FINISHING	TREATMENT	MATERIAL	QUANTITY	CUSTOMER
(塗)	塗装	SS400	1	
SCALE	1/4	DATE		
DESIGNER		DR		
CHECKER				
APPROVER				
PARTS NAME	A-5用梁台			
PARTS NO.	MA-A-5-K-001			