

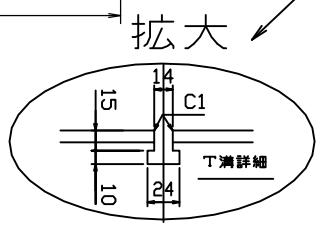

ラム寸法図

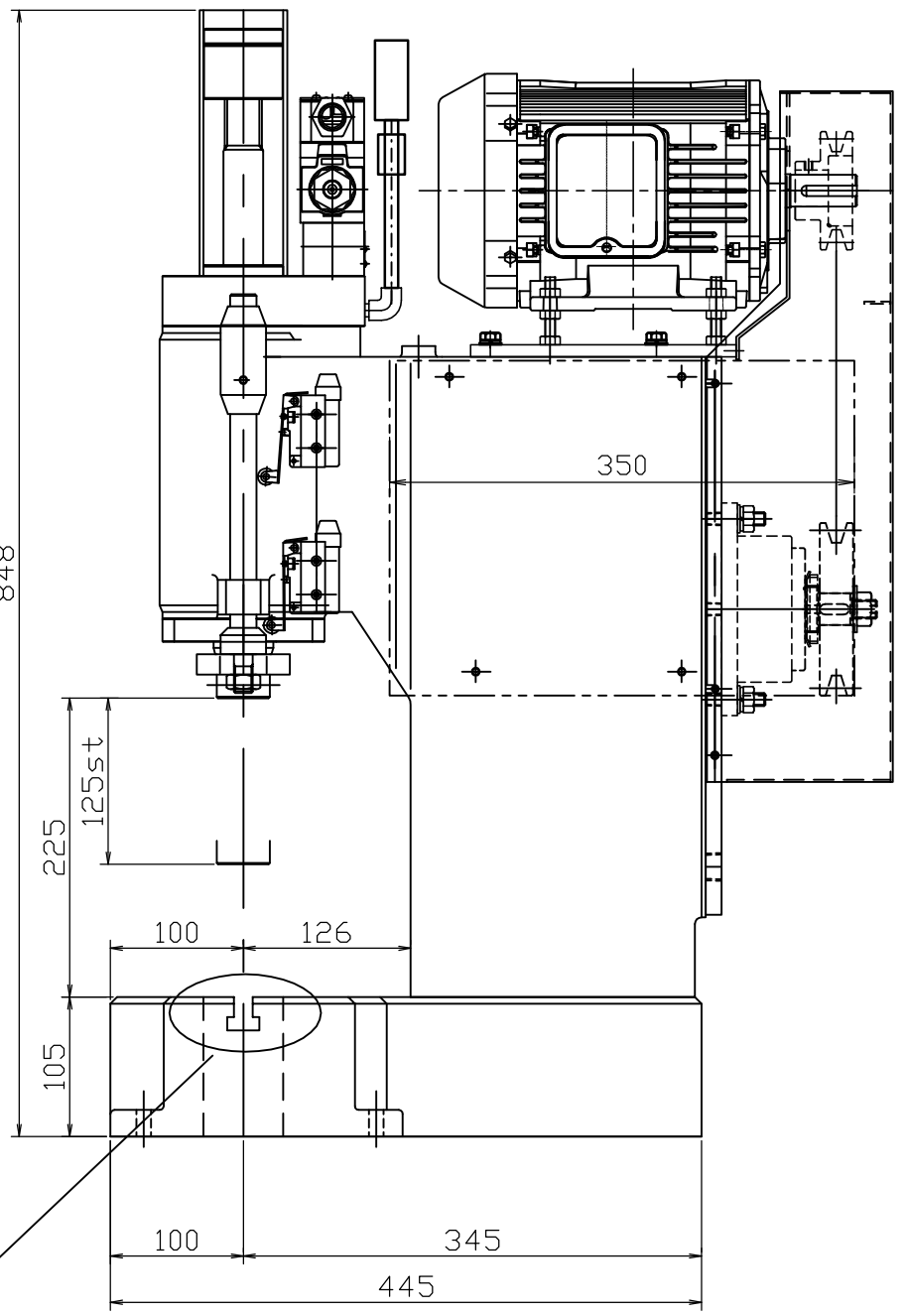

圧力荷重換算表

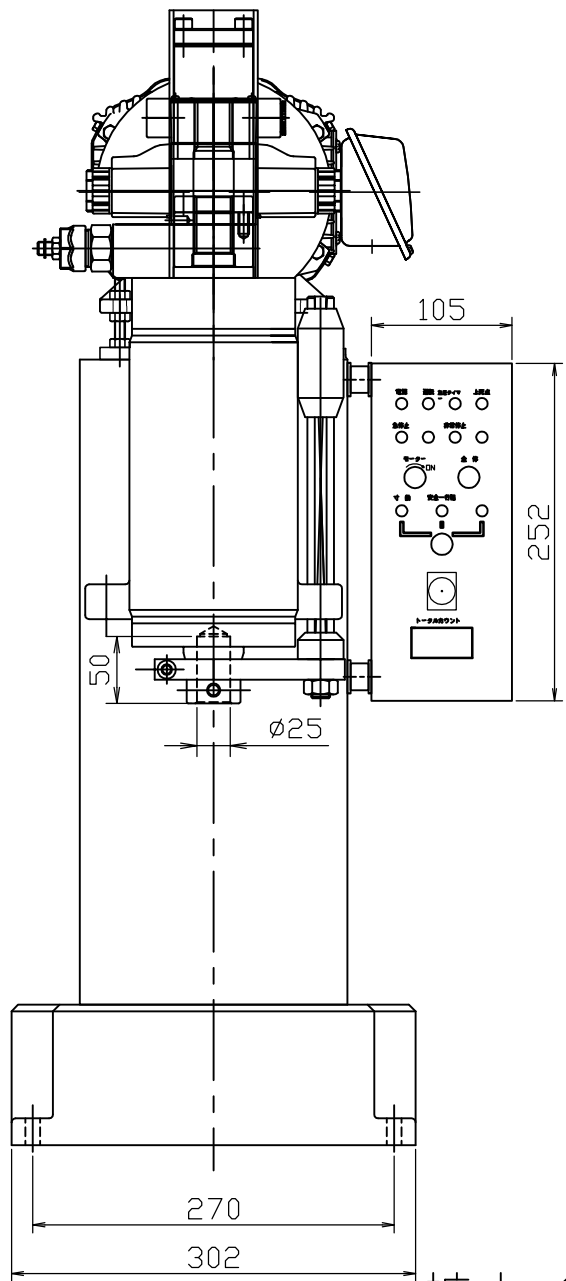
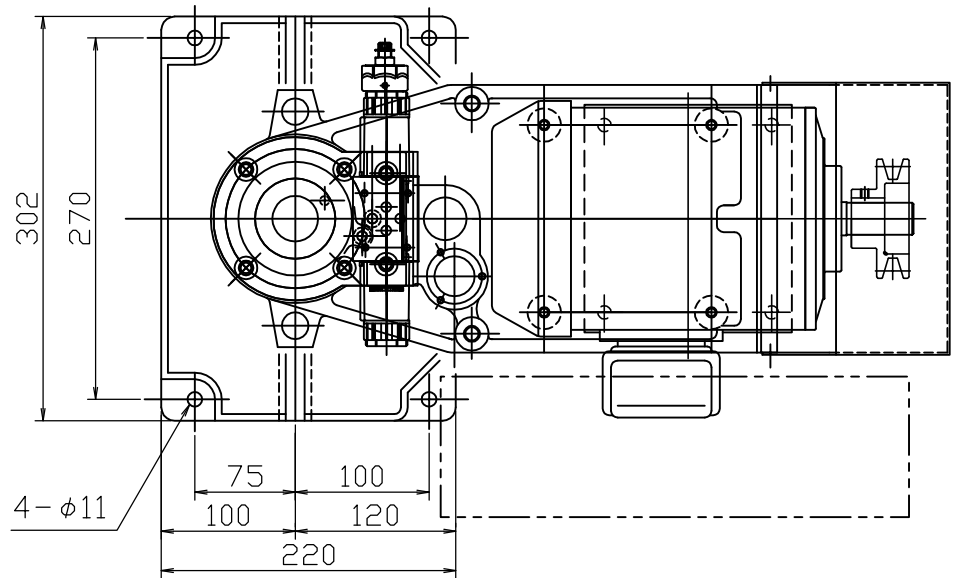
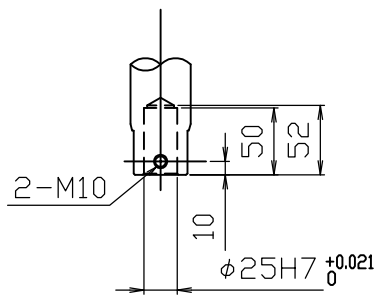
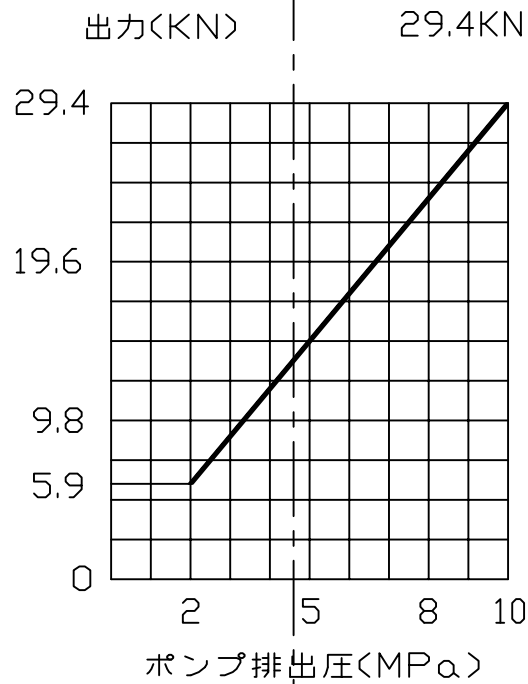

株式会社 マテックス精工

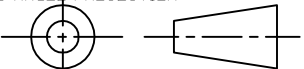
FINISHING		TREATMENT		MATERIAL		QUANTITY		MACHINE NAME	
						1		A-3標準プレス	
△		SCALE		DATE		UNIT NAME			
△		1/1							
△				PARTS NAME					
				銘板<圧力表>					
THIRD ANGLE PROJECTION		CHECKED BY		DESIGNED BY		DRAWN BY		CODE	
						A4		PARTS NO	
								MA-A3-032	

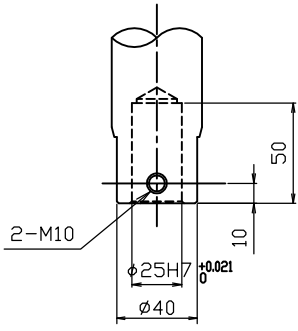

ラム寸法図

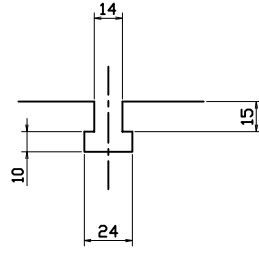

T溝寸法図

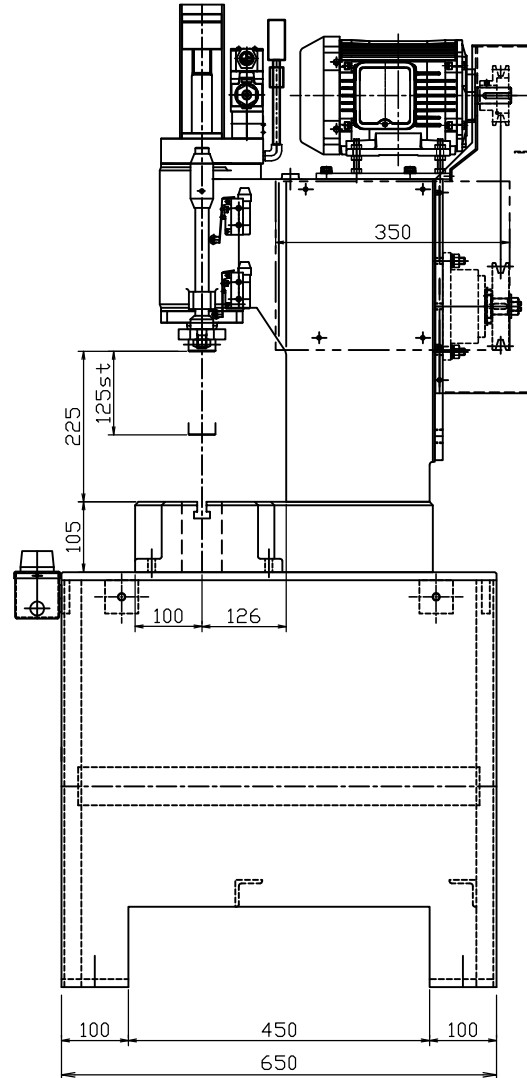
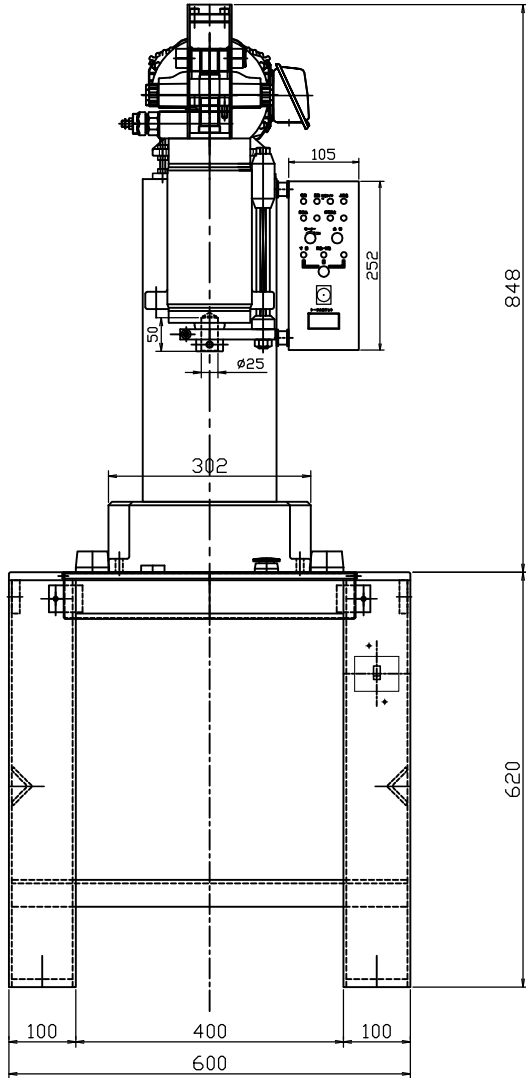
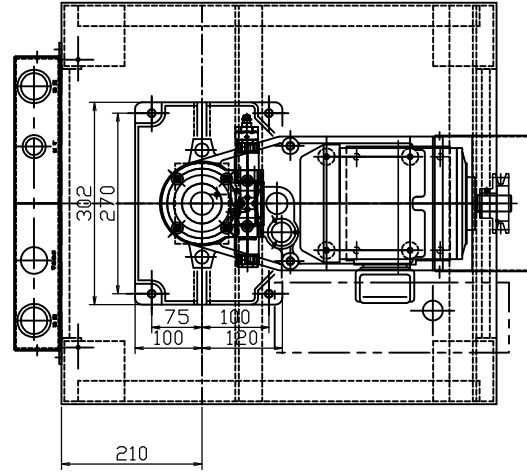

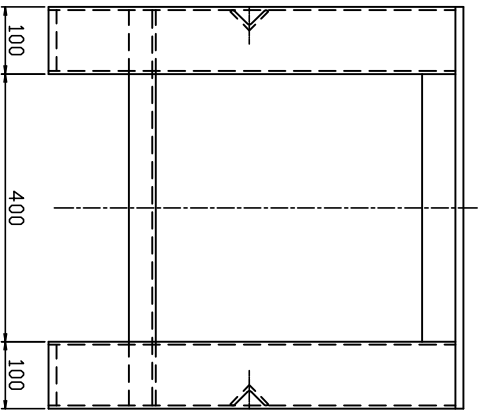

後面

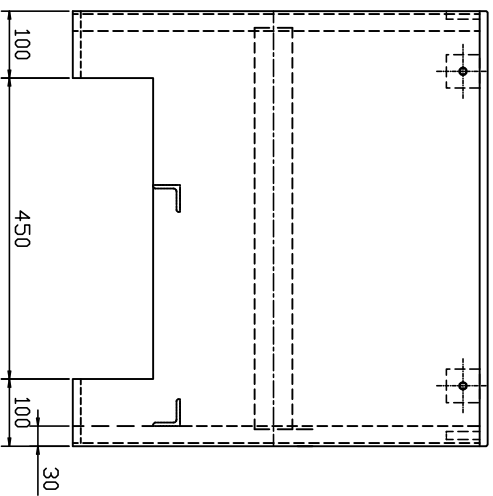
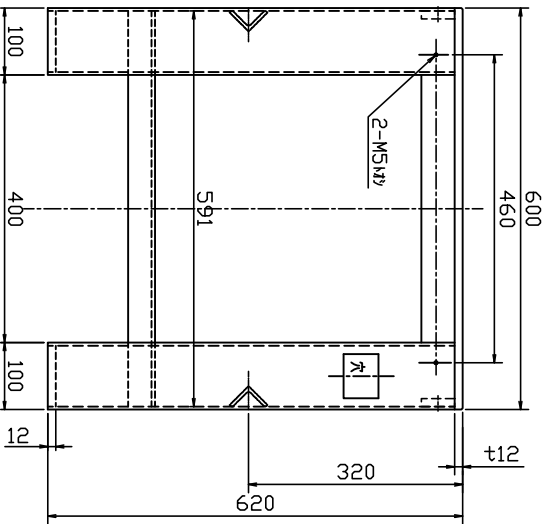
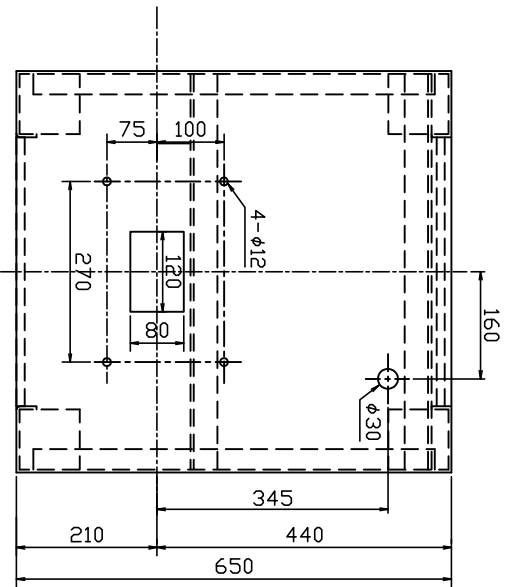
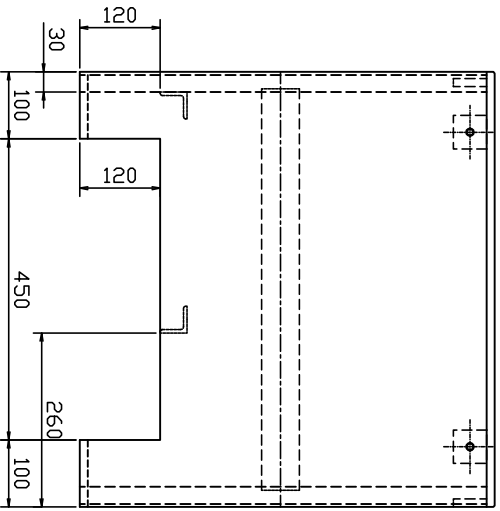

FINISHING	TREATMENT	INTEGRAL	QUANTITY	CUSTOMER
塗装	SS400	1		
SCALE	DATE			
1/4				
UNIT NAME	MACHINE NAME			
架台	H-3型ノリス			
PARTS NAME				
MA-43-024				
PARTS NO				
MA-43-024				