

ラム 寸法図

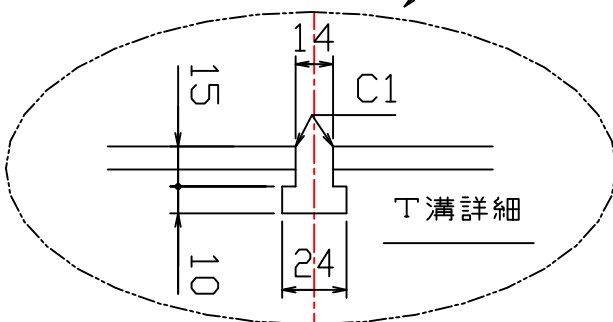
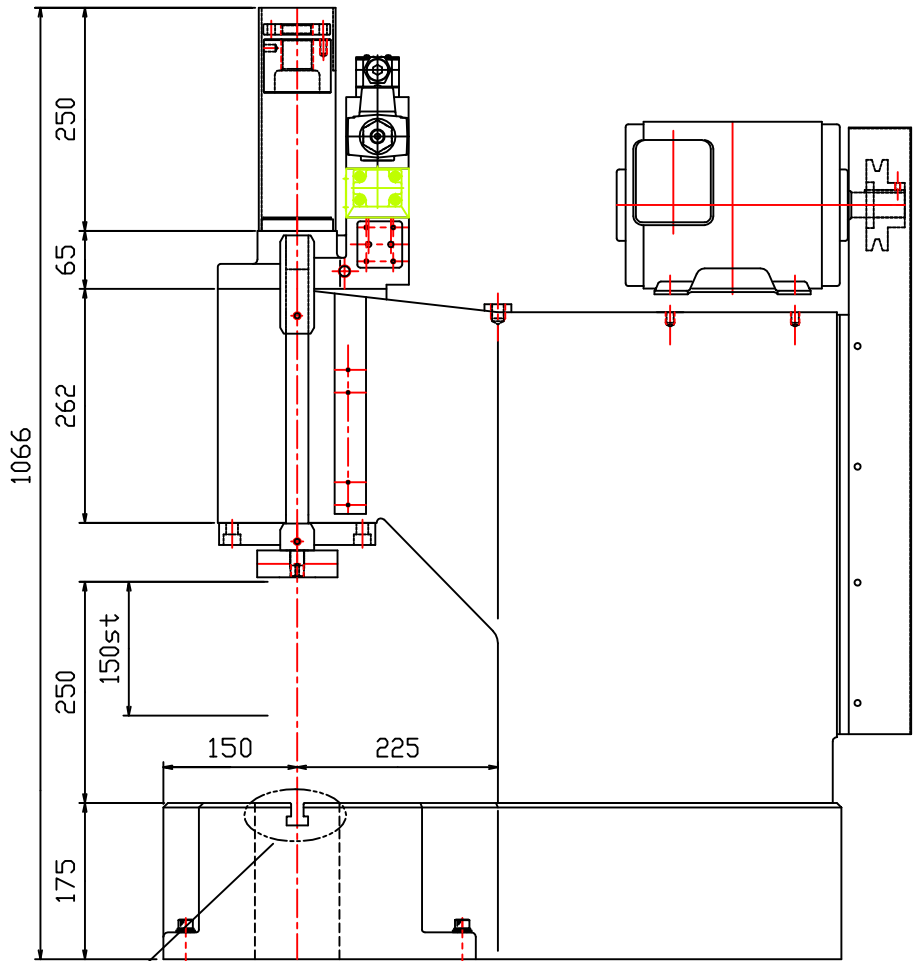
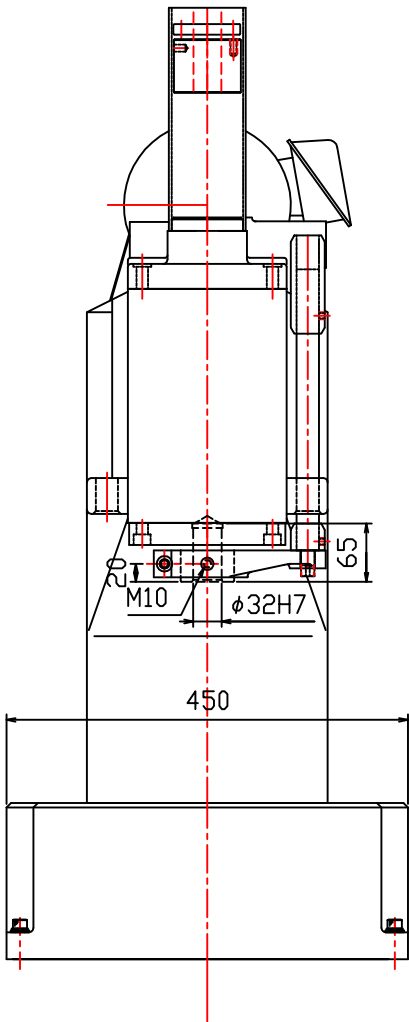
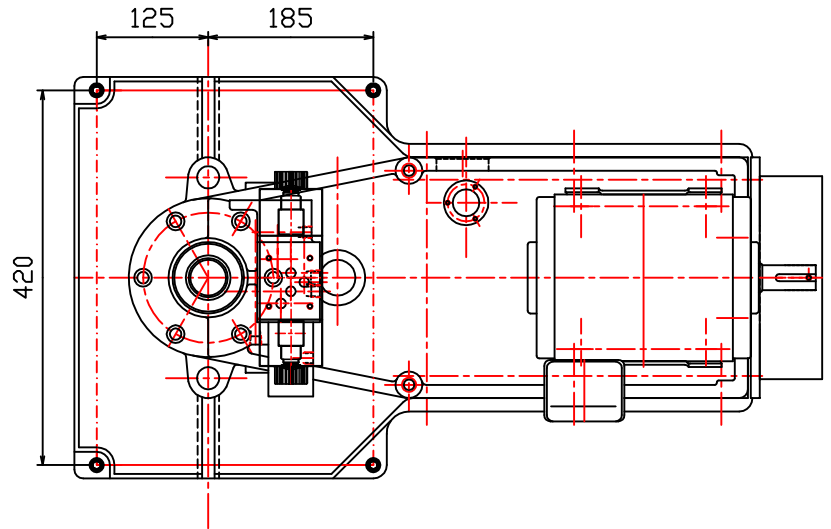
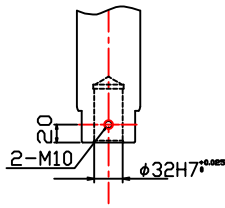

拡大

指示なき角及び後線部は仕上げ時糸面取りのこと(必ず)

FINISHING	TREATMENT	MATERIAL	QUANTITY	MACHINE NAME
				油圧プレス 標準A-10型
SCALE	DATE	UNIT NAME		
1/4				
CHECKED BY		DESIGNED BY	DRAWN BY	PARTS NAME
				外觀図
THIRD ANGLE PROJECTION			DATE	PARTS NO
			A1	

圧力荷重換算表

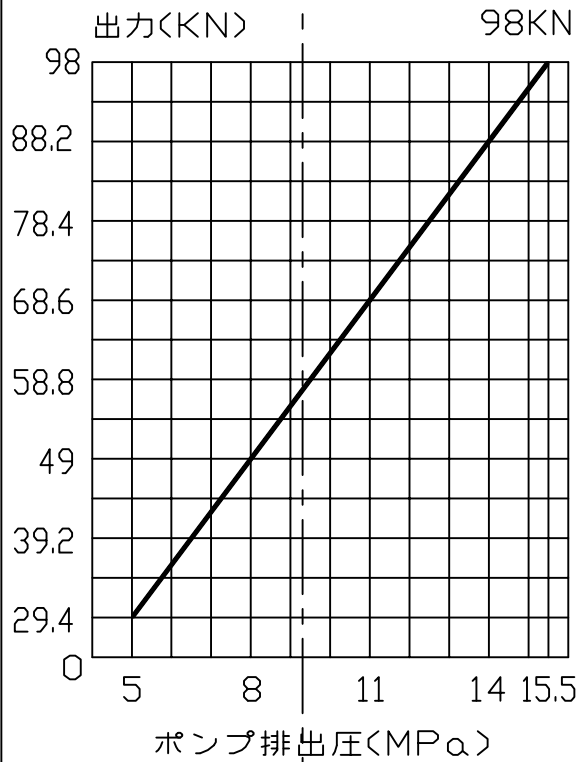

株式会社 マテックス精工

FINISHING		TREATMENT		MATERIAL		QUANTITY	MACHINE NAME	
						1	A-10標準プレス	
△				SCALE	1/1	DATE	UNIT NAME	
△				MATEX			PARTS NAME	
△							銘板(圧力表)	
THIRD ANGLE PROJECTION				CHECKED BY	DESIGNED BY	DRAWN BY	CODE	PARTS NO
						A4		A10-032

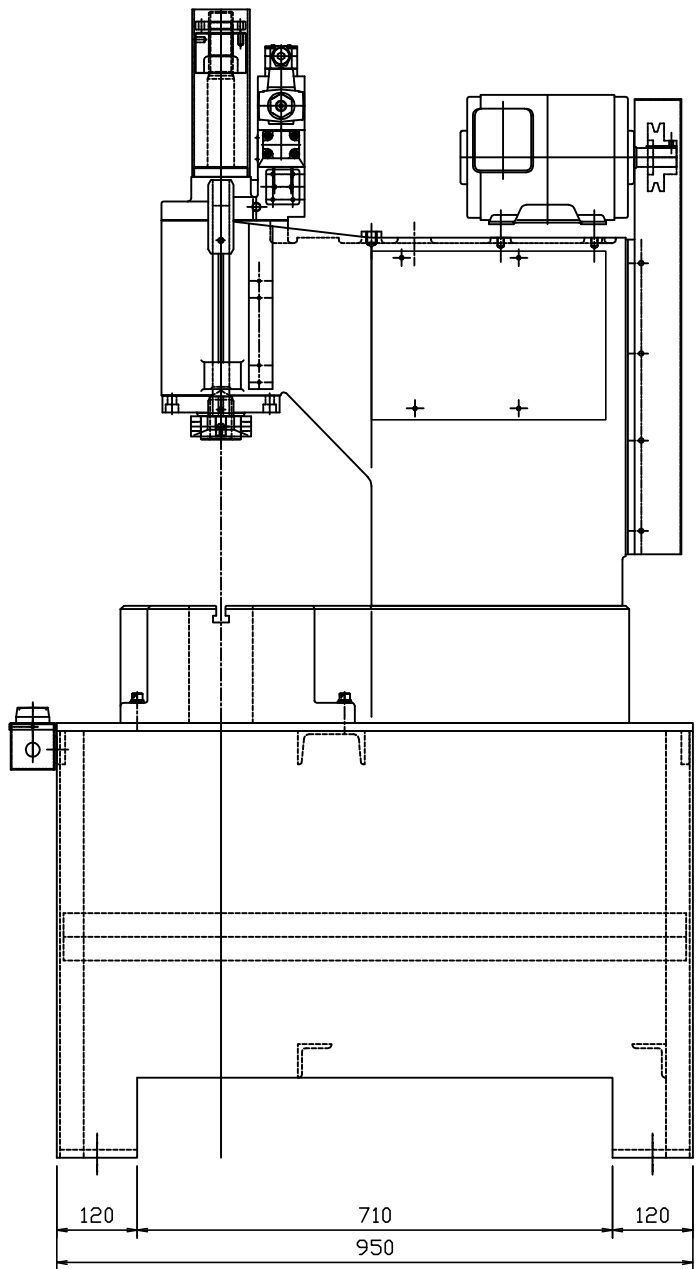
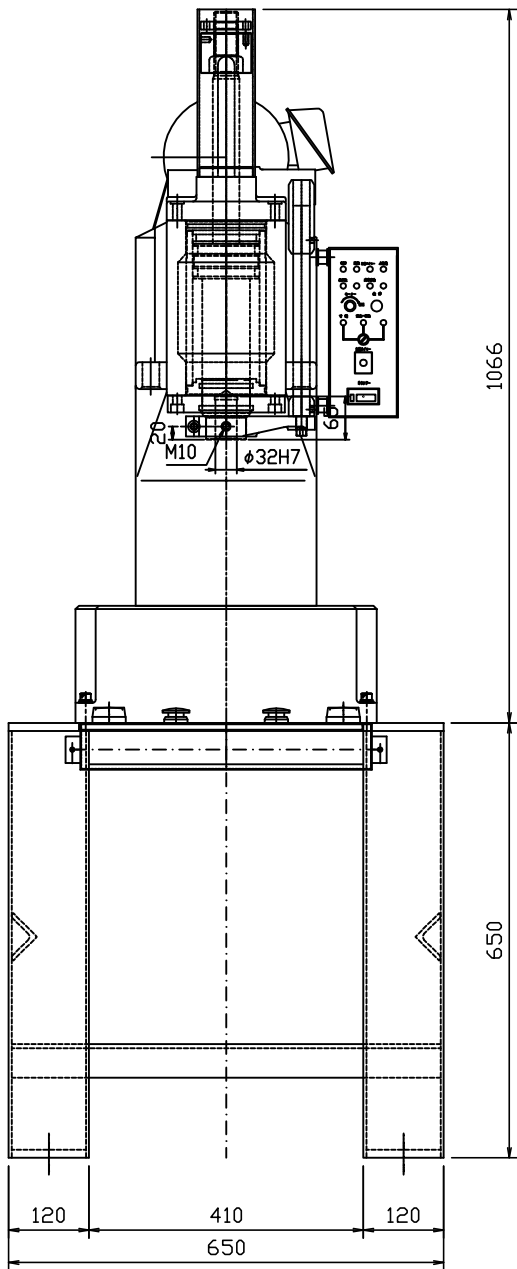
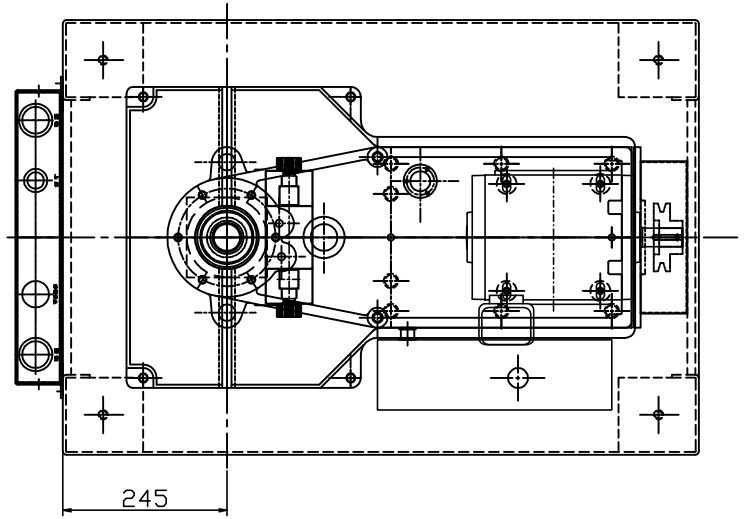

FINISHING	TREATMENT	MATERIAL	QUANTITY	MACHINE NAME
				A-10型プレス
△		SCALE 1/4	DATE	UNIT NAME
△		MATEX		PARTS NAME 外観図
THIRD ANGLE PROJECTION		CHECKED BY	DESIGNED BY	DRAWN BY
				CODE PARTS NO

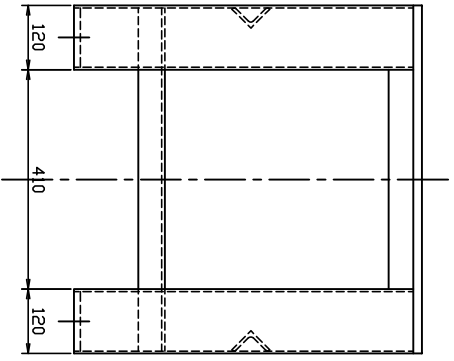

後面

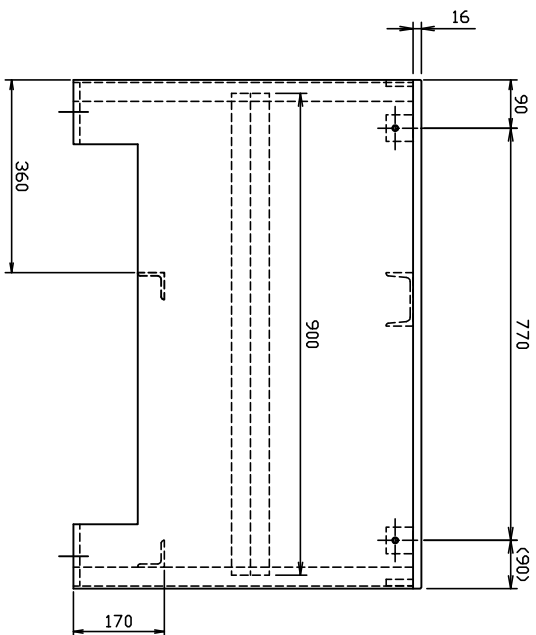
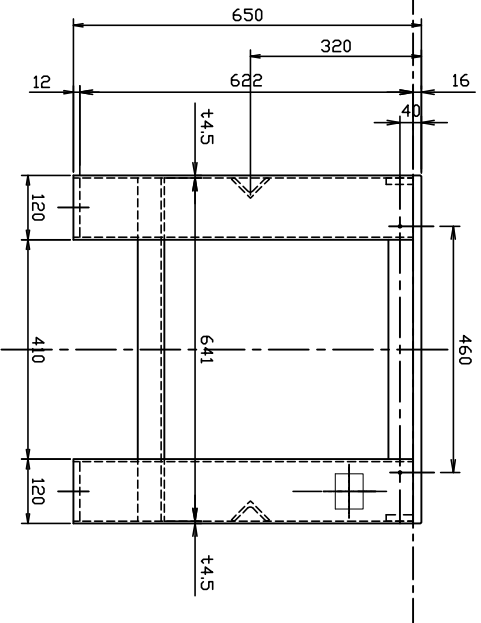
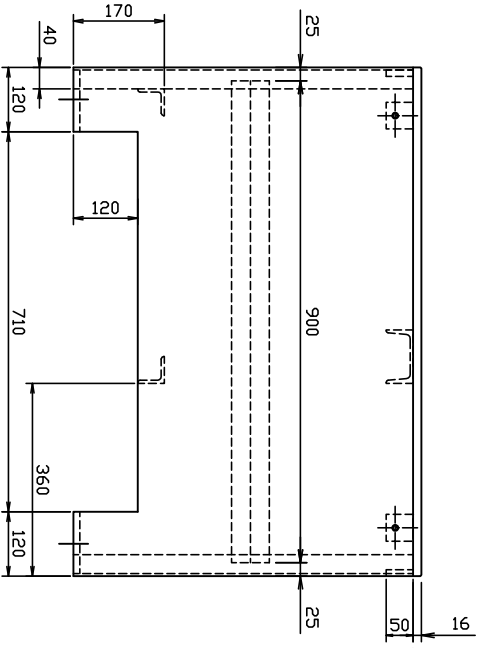
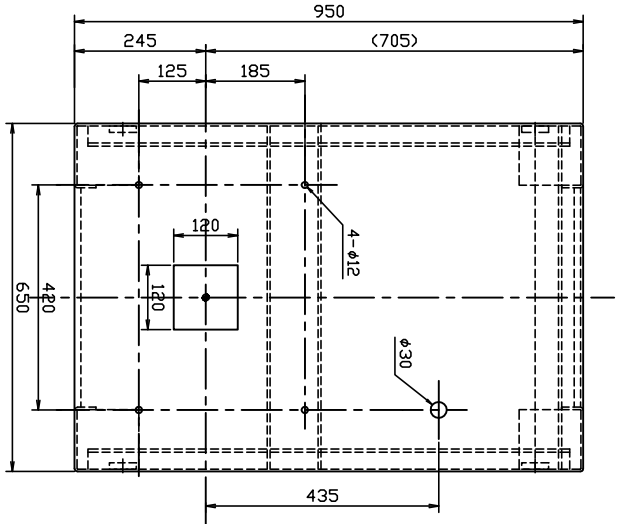

指示がキ面A1005トZJV

FINISHING	TREATMENT	MATERIAL	QUANTITY/CUSTOMER
△	塗装	SS400	1
△	SCALE	1/5	DATE
△	NO. OF SHEETS	1	
△	REVISION		
△	UNIT NAME	MACHINE NAME	CUSTOMER NAME
△		A-107V3	
△	PARTS NAME	A-10用梁台	
△	PARTS NO	A10-001	